

KMK USB Project Board PC Operation Manual V1.1

Introduction

The KMK Project Board PC is a ready to use PC Control IO card with 8 digital outputs, 8 digital inputs and 14 RC servos with 180 steps resolution. It is an ideal tool for learning and building all kinds of computer control projects.

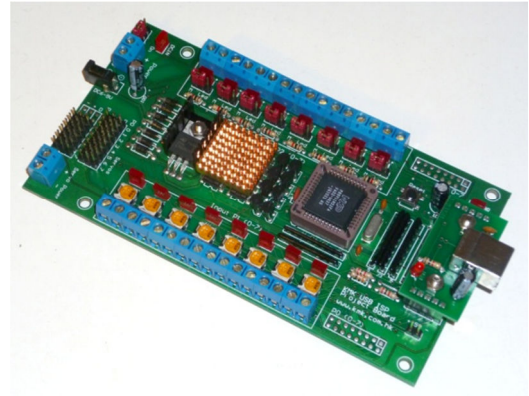

Features

- Control with PC via USB cable.
- OCX Control allows writing programs easily.
- Multiple KMK Project Board PC IO Cards can be used simultaneously.
- Control 8 DC 6v-9v devices up to 500mA.
- Control up to 14 RC Servos with 180 steps resolution.
- Read 8 digital signals from switches and LDRs.
- Build in trimmer for adjusting sensitivity of LDRs.
- Operated with DC 6V - 9V.

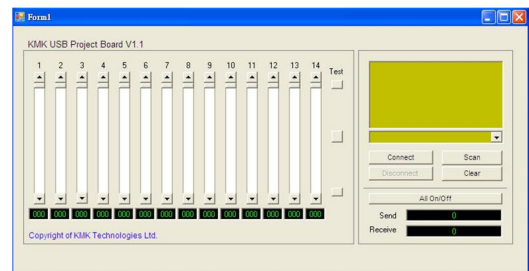

Parts of Project Board

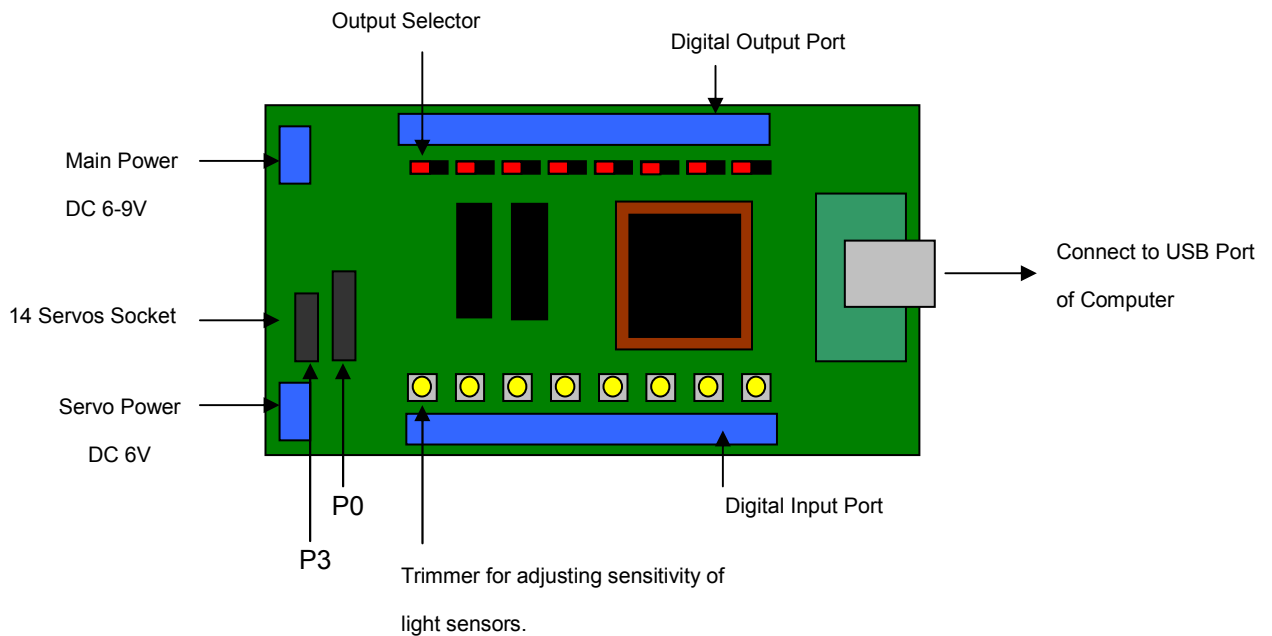

Hardware connections examples

1. Driving DC Motors

1.1 Output port can control ON/OFF of eight DC motors.

A 104 (0.1u) capacitor is recommended to use on each motor.

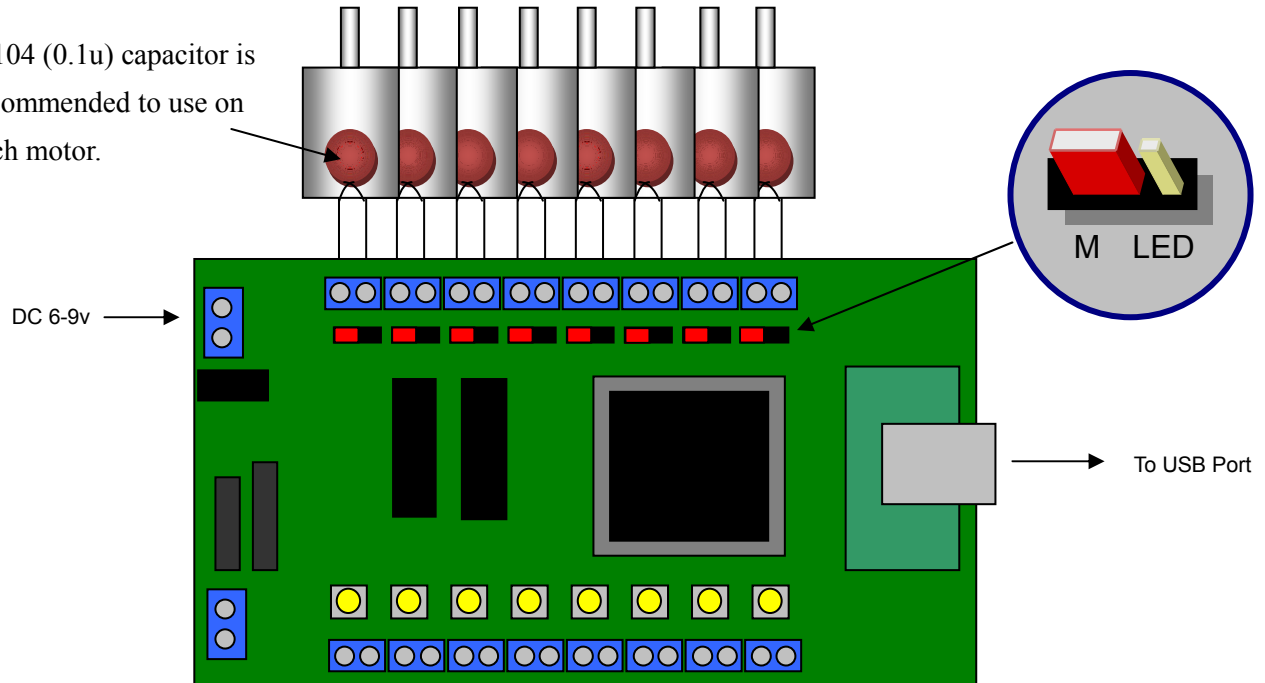

1.2 Two outputs pins are used to control DC motor to turn in different directions.

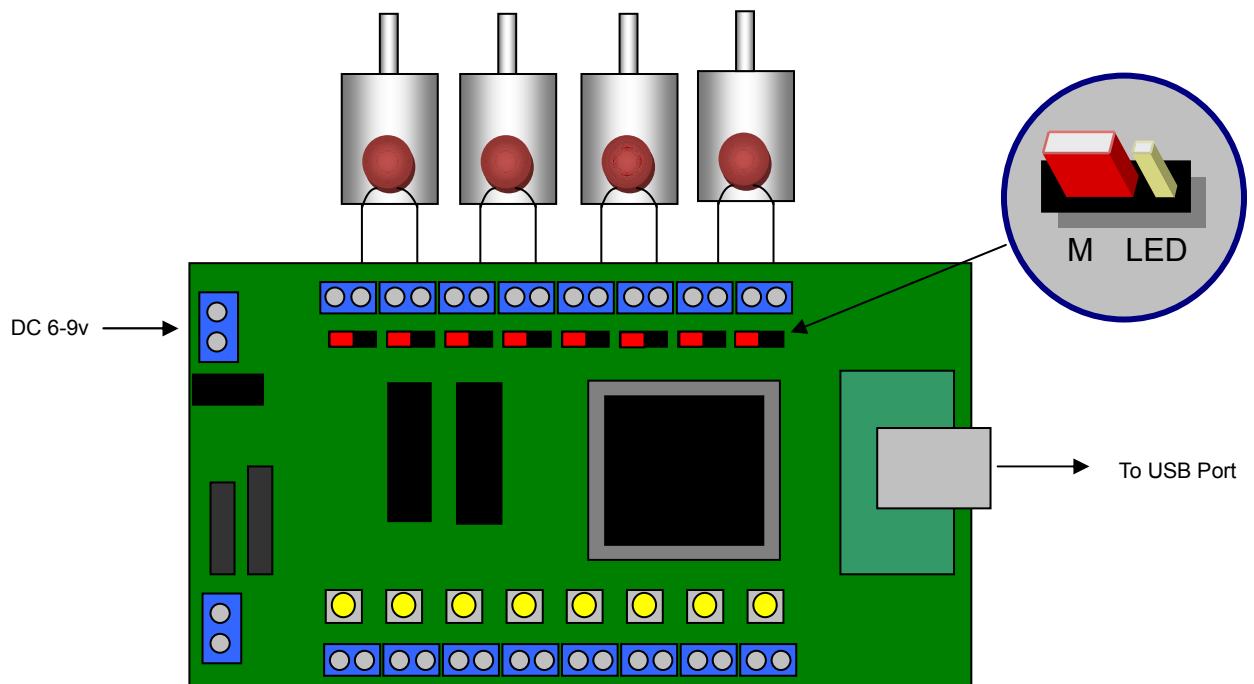

2. Driving LEDs

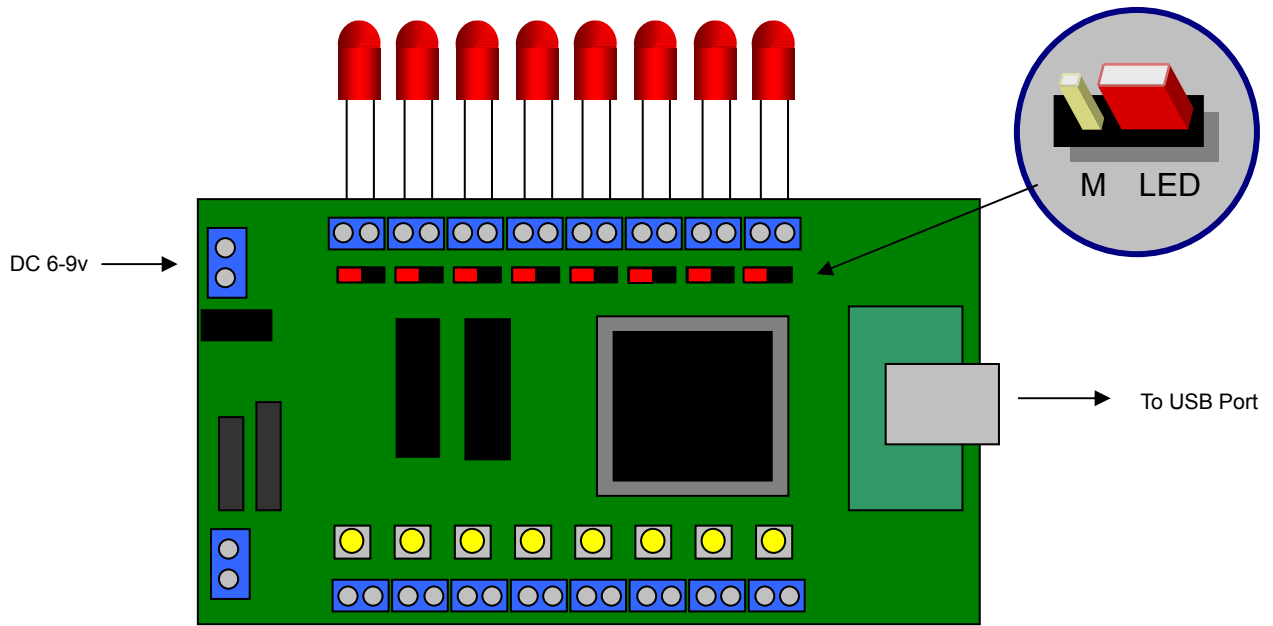

3. Controlling RC Servos

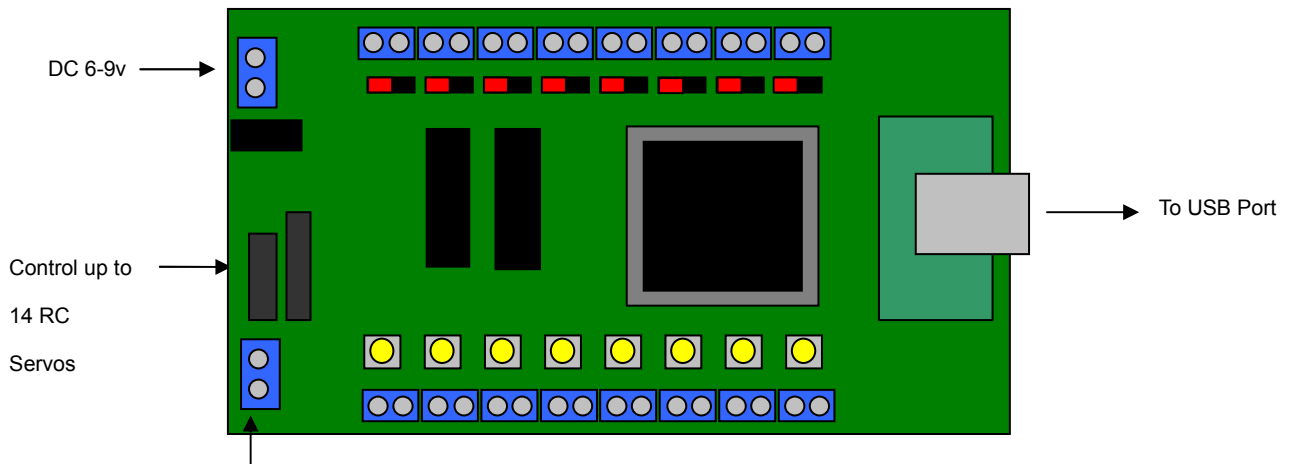

DC 6V (Do not exist 6V otherwise the RC servos will be damaged.)

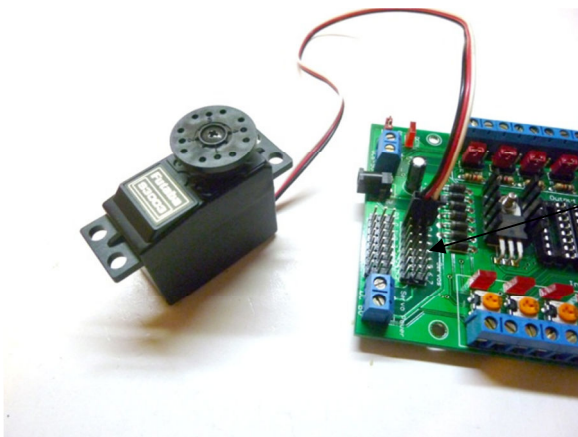

Servo Sockets pin out;

- + 5-6V (Servo Red)
- GND (Servo Black)
- D Data line (Servo White)

4. Use of LDR (Light Dependence Resistors) as input device.

Note: The trimmers are used for adjusting the sensitivity of the LDRs. Totally 8 LDRs can be used.

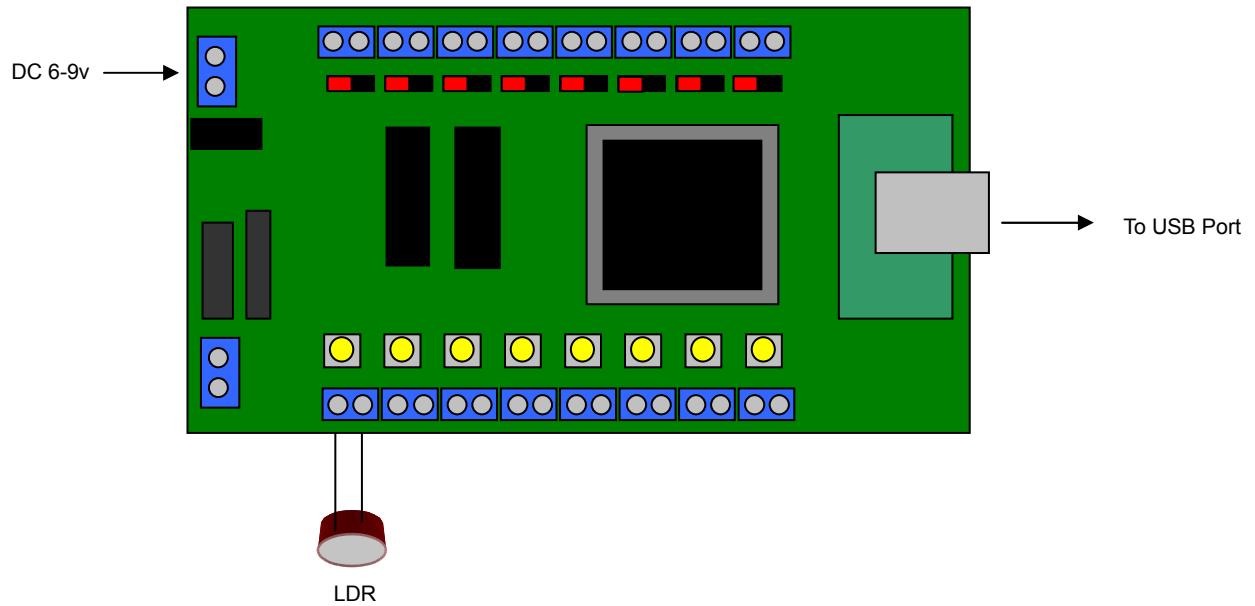

5. Use of Micro Switches as input devices.

Note: NO (Normal Open) or NC (Normal Close) Switches can also be used.

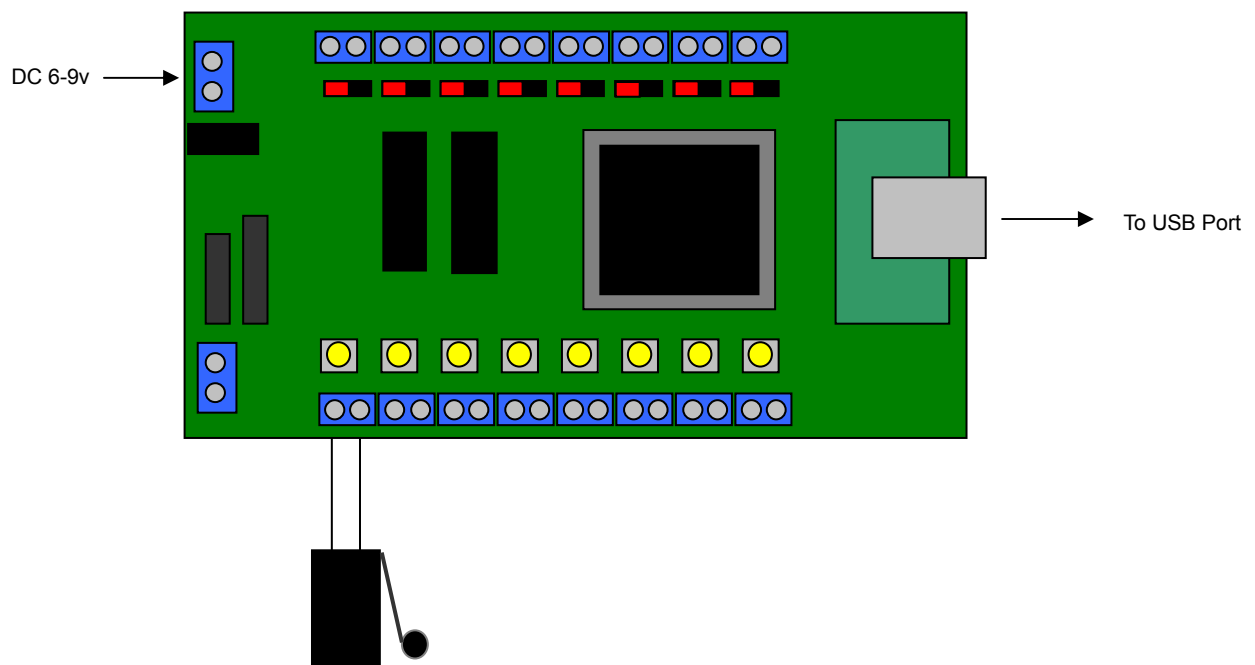

Getting Start

Install the USB Driver

1. Connect to any USB port of the PC.
2. On the right hand corner of Windows will display a message “KMK Project Board PC” and prompt for installing the driver.
3. Browse to the driver folder of the CD and click “OK” and the drivers will be installed automatically.

Note: you may found the latest USB Driver on our web site www.kmk.com.hk.

Install the KMK Project Board PC OCX Control

1. Browse to the OCX folder.
2. Double click setup.exe
3. Follow the setup wizard to finish the set up of the OCX control.

Note: The OCX Control is used for writing computer control programs with Visual Studio. The functions of the IO card can be controlled directly on the OCX Panel or by writing program code. Please refer to program examples in the following pages.

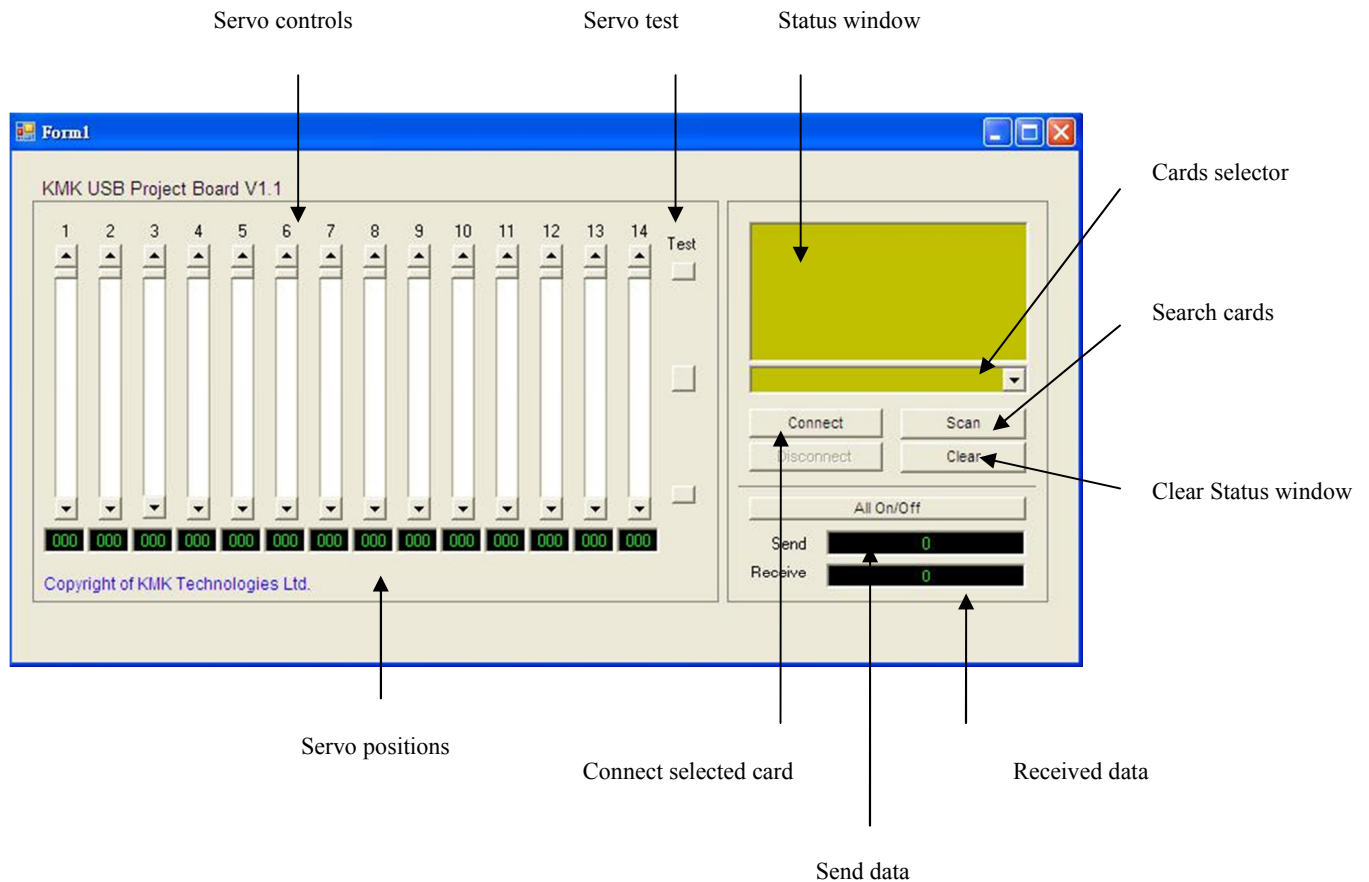

KMK Project Board PC OCX Control Command List

| Command | Examples | Usage |
|-------------------------------|--------------------------------------|----------------------------------|
| AxKMKPRBRDPC1.Device | AxKMKPRBRDPC1.Device = "KMKSERIAL" | Enter serial number |
| AxKMKPRBRDPC1.Port_Open_Close | AxKMKPRBRDPC1.Port_Open_Close = 1 | Connect the IO Card |
| | AxKMKPRBRDPC1.Port_Open_Close = 0 | Disconnect the IO Card |
| AxKMKPRBRDPC1.Status | Textbox1.Text = AxKMKPRBRDPC1.Status | Return the status of the IO Card |
| AxKMKPRBRDPC1.Out | AxKMKPRBRDPC1.Out = 129 | Output a value to the IO Card |
| AxKMKPRBRDPC1.Binary | Textbox1.Text = AxKMKPRBRDPC1.Binary | Return the Input Value |
| AxKMKPRBRDPC1.Servo1 | AxKMKPRBRDPC1.Servo1 = 90 | Move Servo 1 to 90 (0-180) |
| AxKMKPRBRDPC1.Servo2 | AxKMKPRBRDPC1.Servo2 = 90 | Move Servo 2 to 90 (0-180) |
| AxKMKPRBRDPC1.Servo3 | AxKMKPRBRDPC1.Servo3 = 90 | Move Servo 3 to 90 (0-180) |
| AxKMKPRBRDPC1.Servo4 | AxKMKPRBRDPC1.Servo4 = 90 | Move Servo 4 to 90 (0-180) |
| AxKMKPRBRDPC1.Servo5 | AxKMKPRBRDPC1.Servo5 = 90 | Move Servo 5 to 90 (0-180) |
| AxKMKPRBRDPC1.Servo6 | AxKMKPRBRDPC1.Servo6 = 90 | Move Servo 6 to 90 (0-180) |
| AxKMKPRBRDPC1.Servo7 | AxKMKPRBRDPC1.Servo7 = 90 | Move Servo 7 to 90 (0-180) |
| AxKMKPRBRDPC1.Servo8 | AxKMKPRBRDPC1.Servo8 = 90 | Move Servo 8 to 90 (0-180) |
| AxKMKPRBRDPC1.Servo9 | AxKMKPRBRDPC1.Servo9 = 90 | Move Servo 9 to 90 (0-180) |
| AxKMKPRBRDPC1.Servo10 | AxKMKPRBRDPC1.Servo10 = 90 | Move Servo 10 to 90 (0-180) |
| AxKMKPRBRDPC1.Servo11 | AxKMKPRBRDPC1.Servo11 = 90 | Move Servo 11 to 90 (0-180) |
| AxKMKPRBRDPC1.Servo12 | AxKMKPRBRDPC1.Servo12 = 90 | Move Servo 12 to 90 (0-180) |
| AxKMKPRBRDPC1.Servo13 | AxKMKPRBRDPC1.Servo13 = 90 | Move Servo 13 to 90 (0-180) |
| AxKMKPRBRDPC1.Servo14 | AxKMKPRBRDPC1.Servo14 = 90 | Move Servo 14 to 90 (0-180) |
| AxKMKPRBRDPC1.Visible | AxKMKPRBRDPC1.Visible = False | Hide the OCX |
| | AxKMKPRBRDPC1.Visible = True | Unhide the OCX |

Putting the KMK Project Board PC OCX on Visual Basic

1. Start a new project on Visual Basic.
2. Right click the Tool Box on the Left Hand Side and click **Choose Items...** on the pop up menu.
3. Select the Com Component Page and tick the KMK Project Board PC OCX.
4. The OCX will be listed on the Tool Box
5. Select the OCX and Drag it to the Form.
6. Adjust the size and position of it.
7. It is ready to use.

Program examples using Microsoft Visual Studio

1. Driving 8 Leds

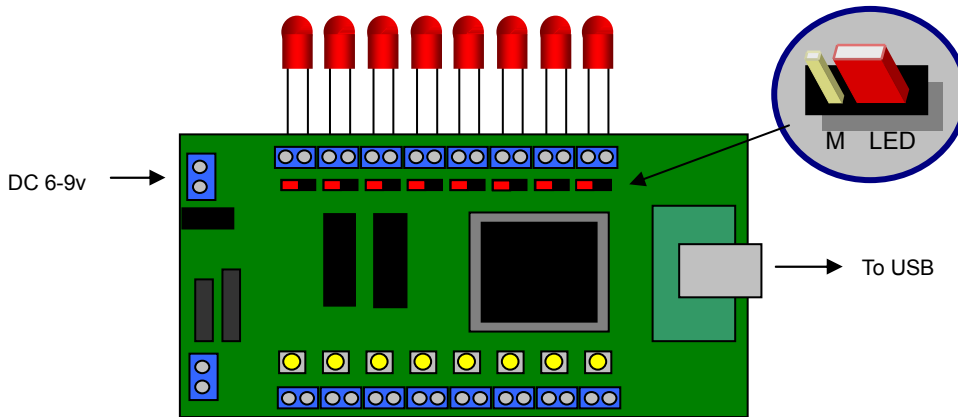

1.1. Start a new project on Visual Basic and put the OCX on the form. On the **Form Load** event type the code below;

AxKMKPRBRDPC1.Device = "xxxxxxx" 'xxxxxxx is the serial number of the IO Card.

AxKMKPRBRDPC1.Port_Open_Close = 1 'Connect the Card.

1.2. Put 8 Buttons on the Form, name the buttons to LED 1, LED 2... respectively.

1.3 Enter the code for the buttons as the table below;

| Buttons | Commands | Usage |
|---------|-------------------------|-------------------------|
| LED 1 | AxKMKPRBRDPC1.Out = 1 | 'Switch on first LED. |
| LED 2 | AxKMKPRBRDPC1.Out = 2 | 'Switch on second LED. |
| LED 3 | AxKMKPRBRDPC1.Out = 4 | 'Switch on third LED. |
| LED 4 | AxKMKPRBRDPC1.Out = 8 | 'Switch on fourth LED. |
| LED 5 | AxKMKPRBRDPC1.Out = 16 | 'Switch on fifth LED. |
| LED 6 | AxKMKPRBRDPC1.Out = 32 | 'Switch on sixth LED. |
| LED 7 | AxKMKPRBRDPC1.Out = 64 | 'Switch on seventh LED. |
| LED 8 | AxKMKPRBRDPC1.Out = 128 | 'Switch on eighth LED. |

1.4 Run the program and the card should be connected when the program start. Click the buttons and the LED light up according to the button clicked.

2. Driving 8 DC Motors

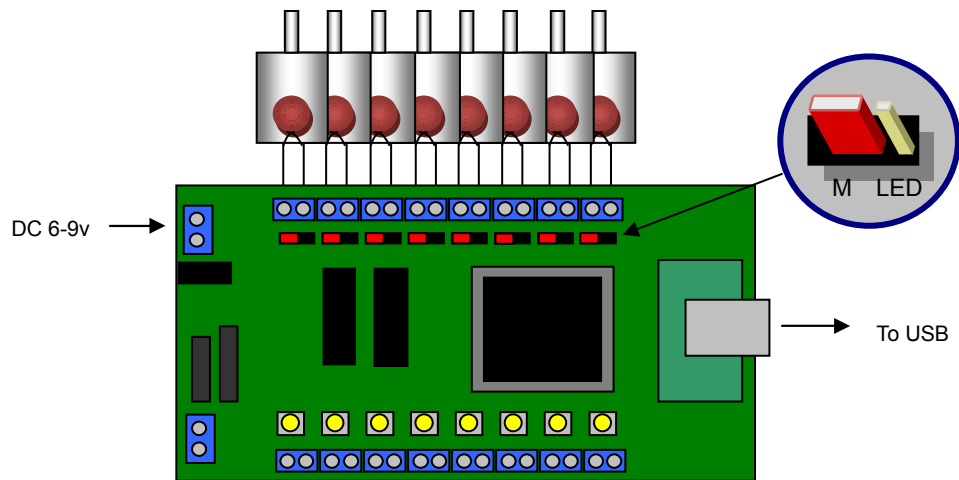

2.1. Start a new project on Visual Basic and put the OCX on the form. On the **Form Load** event type the code below;

AxKMKPRBRDPC1.Device = "xxxxxxx" 'xxxxxxx is the serial number of the IO Card.

AxKMKPRBRDPC1.Port_Open_Close = 1 'Connect the Card.

2.2. Put 8 Buttons on the Form, name the buttons to Motor 1, Motor 2... respectively.

2.3 Enter the code for the buttons as the table below;

| Buttons | Commands | Usage |
|---------|-------------------------|---------------------------|
| Motor 1 | AxKMKPRBRDPC1.Out = 1 | 'Switch on first Motor. |
| Motor 2 | AxKMKPRBRDPC1.Out = 2 | 'Switch on second Motor. |
| Motor 3 | AxKMKPRBRDPC1.Out = 4 | 'Switch on third Motor. |
| Motor 4 | AxKMKPRBRDPC1.Out = 8 | 'Switch on fourth Motor. |
| Motor 5 | AxKMKPRBRDPC1.Out = 16 | 'Switch on fifth Motor. |
| Motor 6 | AxKMKPRBRDPC1.Out = 32 | 'Switch on sixth Motor. |
| Motor 7 | AxKMKPRBRDPC1.Out = 64 | 'Switch on seventh Motor. |
| Motor 8 | AxKMKPRBRDPC1.Out = 128 | 'Switch on eighth Motor. |

2.4 Run the program and the card should be connected when the program start. Click the buttons and the Motors start turning according to the button clicked.

Note: As you can see the program code for switching on LED and DC Motor is the same. All we have to do is to change the jumper for adjusting the hardware and provide more driving current to the motors.

Note: if you want to switch two or more LEDs/motors, just add the value together. e.g. switch on first , third and fifth LEDs/motors we use AxKMKPRBRDPC1.Out = 1 + 4 + 16 or AxKMKPRBRDPC1.Out = 21, etc.

3. Driving 4 DC Motors

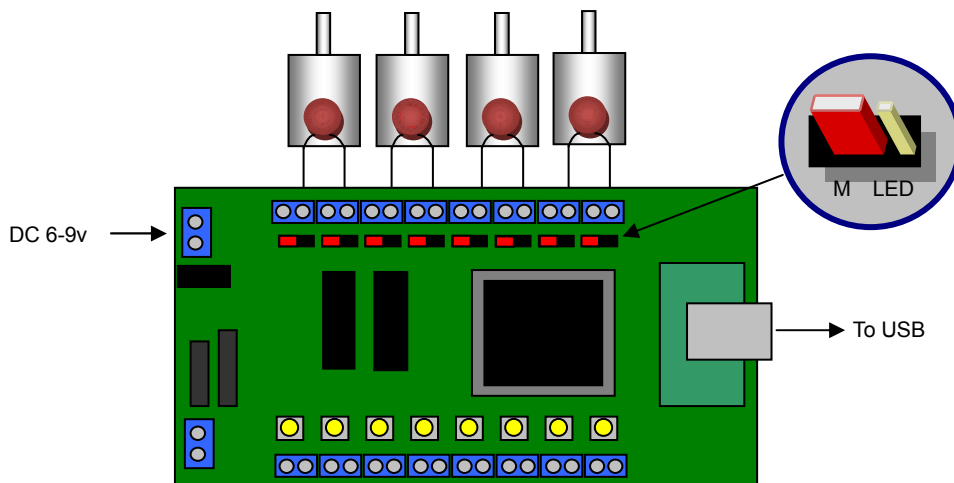

We use two output port pins to control each motor, and the on/off of these two ports pins can turn the DC motor in two directions. Turn both on/off stop the motor.

3.1. Start a new project on Visual Basic and put the OCX on the form. On the **Form Load** event type the code below;

AxKMKPRBRDPC1.Device = "xxxxxxx" 'xxxxxxx is the serial number of the IO Card.

AxKMKPRBRDPC1.Port_Open_Close = 1 'Connect the Card.

3.2 Put 12 buttons on the form and enter the code of the buttons as the table below;

| Buttons | Command | Usage |
|--------------|------------------------------|-------------------|
| Motor 1 CW | AxKMKPRBRDPC1.Out = 1 | 'turn Motor 1 CW |
| Motor 1 CCW | AxKMKPRBRDPC1.Out = 2 | 'turn Motor 1 CCW |
| Motor 1 Stop | AxKMKPRBRDPC1.Out = 1+2 | 'stop Motor 1 |
| Motor 2 CW | AxKMKPRBRDPC1.Out = 4 | 'turn Motor 2 CW |
| Motor 2 CCW | AxKMKPRBRDPC1.Out = 8 | 'turn Motor 2 CCW |
| Motor 2 Stop | AxKMKPRBRDPC1.Out = 4+8 | 'stop Motor 2 |
| Motor 3 CW | AxKMKPRBRDPC1.Out = 16 | 'turn Motor 3 CW |
| Motor 3 CCW | AxKMKPRBRDPC1.Out = 32 | 'turn Motor 3 CCW |
| Motor 3 Stop | AxKMKPRBRDPC1.Out = 16 + 32 | 'stop Motor 3 |
| Motor 4 CW | AxKMKPRBRDPC1.Out = 64 | 'turn Motor 4 CW |
| Motor 4 CCW | AxKMKPRBRDPC1.Out = 128 | 'turn Motor 4 CCW |
| Motor 4 Stop | AxKMKPRBRDPC1.Out = 64 + 128 | 'stop Motor 4 |

3.3 Run the program and the card should be connected when the program start. Click the buttons and the Motors start turning in the directions according to the buttons clicked.

3. Control RC Servos

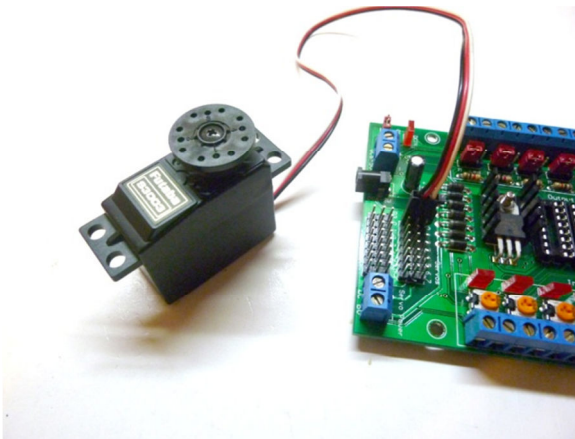

3.1 Connect 5 RC Servos to the KMK Project Board PC. We are going to write a program to move the servos to different positions.

3.2 Start a new project on Visual Basic and put the OCX on the form. On the **Form Load** event type the code below;

```
AxKMKPRBRDPC1.Device = "xxxxxxx" 'xxxxxxx is the serial number of the IO Card.
```

```
AxKMKPRBRDPC1.Port_Open_Close = 1 'Connect the Card.
```

3.3 Put a button on the form, double click the button and enter the code as below;

```
Dim i as byte
```

```
For i = 0 to 180 step 10
```

```
AxKMKPRBRDPC1.Servo1= i
```

```
AxKMKPRBRDPC1.Servo2= i
```

```
AxKMKPRBRDPC1.Servo3= i
```

```
AxKMKPRBRDPC1.Servo4= i
```

```
AxKMKPRBRDPC1.Servo5= i
```

```
AxKMKPRBRDPC1.waitms (200)
```

```
Next i
```

3.4 Run the program and click the button, the RC Servos move from 0 to 180 in the step of 10. You can try to change step 10 to smaller value and observe the difference.

4. Reading LDR Input signals

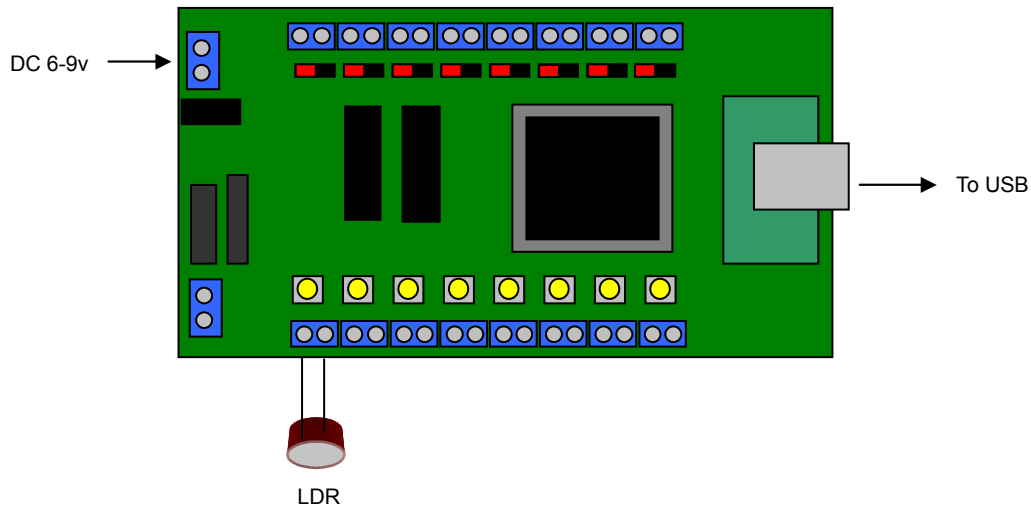

4.1 Connect 8 LDRs to the KMK Project Board PC. We are going to write a program to read the status of the LDRs.

4.2 Start a new project on Visual Basic and put the OCX on the form. On the **Form Load** event type the code below;

AxKMKPRBRDPC1.Device = "xxxxxxx" 'xxxxxxx is the serial number of the IO Card.

AxKMKPRBRDPC1.Port_Open_Close = 1 'Connect the Card.

4.3 Put a timer on the form which is used for scanning the input status of the KMK Project Board PC OCX as we can see the status of the receive text box.

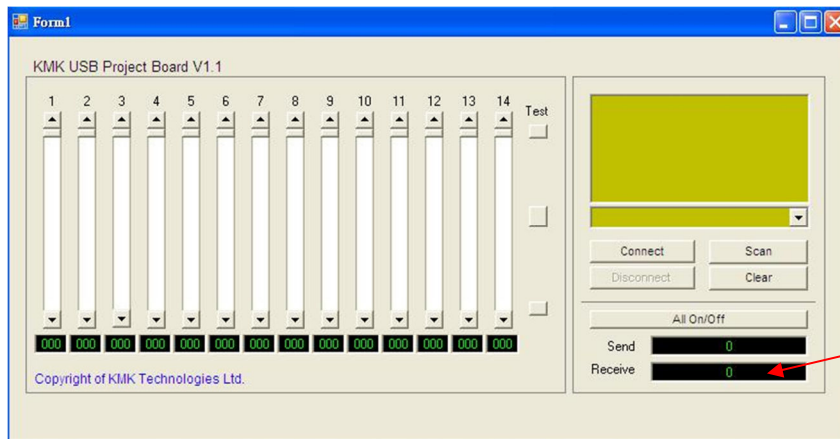

Receive text box shows the input data.

4.4 Set the Timer property Enable to True in order to start the timer. By default, the timer program runs every 100ms. (We can change this by changing the value of Interval property. e.g.1000 = 1S, etc.)

4.5 Below is the code to read the input data and output a value according to the data received.

5. Putting them all together

Please check our web site from time to time for any update information.

Web Site: www.kmk.com.hk

Email: info@kmk.com.hk